

Extron® Electronics

INTERFACING, SWITCHING AND DISTRIBUTION



User's Guide



MTP 1500RL 15HD A and MTP 1500RL 15HD A SEQ

Extended Distance Mini Twisted Pair Receivers

68-1554-01
Rev. A
06 09

Precautions

Safety Instructions • English



This symbol is intended to alert the user of important operating and maintenance (servicing) instructions in the literature provided with the equipment.



This symbol is intended to alert the user of the presence of uninsulated dangerous voltage within the product's enclosure that may present a risk of electric shock.

Caution

Read Instructions • Read and understand all safety and operating instructions before using the equipment.

Retain Instructions • The safety instructions should be kept for future reference.

Follow Warnings • Follow all warnings and instructions marked on the equipment or in the user information.

Avoid Attachments • Do not use tools or attachments that are not recommended by the equipment manufacturer because they may be hazardous.

Consignes de Sécurité • Français



Ce symbole sert à avertir l'utilisateur que la documentation fournie avec le matériel contient des instructions importantes concernant l'exploitation et la maintenance (réparation).



Ce symbole sert à avertir l'utilisateur de la présence dans le boîtier de l'appareil de tensions dangereuses non isolées posant des risques d'électrocution.

Attention

Lire les instructions • Prendre connaissance de toutes les consignes de sécurité et d'exploitation avant d'utiliser le matériel.

Conserver les instructions • Ranger les consignes de sécurité afin de pouvoir les consulter à l'avenir.

Respecter les avertissements • Observer tous les avertissements et consignes marqués sur le matériel ou présentés dans la documentation utilisateur.

Éviter les pièces de fixation • Ne pas utiliser de pièces de fixation ni d'outils non recommandés par le fabricant du matériel car cela risquerait de poser certains dangers.

Sicherheitsanleitungen • Deutsch



Dieses Symbol soll dem Benutzer in der im Lieferumfang enthaltenen Dokumentation besonders wichtige Hinweise zur Bedienung und Wartung (Instandhaltung) geben.



Dieses Symbol soll den Benutzer darauf aufmerksam machen, daß im Inneren des Gehäuses dieses Produktes gefährliche Spannungen, die nicht isoliert sind und die einen elektrischen Schock verursachen können, herrschen.

Achtung

Lesen der Anleitungen • Bevor Sie das Gerät zum ersten Mal verwenden, sollten Sie alle Sicherheits- und Bedienungsanleitungen genau durchlesen und verstehen.

Aufbewahren der Anleitungen • Die Hinweise zur elektrischen Sicherheit des Produktes sollen Sie aufbewahren, damit Sie im Bedarfsfall darauf zurückgreifen können.

Befolgen der Warnhinweise • Befolgen Sie alle Warnhinweise und Anleitungen auf dem Gerät oder in der Benutzerdokumentation.

Keine Zusatzgeräte • Verwenden Sie keine Werkzeuge oder Zusatzgeräte, die nicht ausdrücklich vom Hersteller empfohlen wurden, da diese eine Gefahrenquelle darstellen können.

Instrucciones de seguridad • Español



Este símbolo se utiliza para advertir al usuario sobre instrucciones importantes de operación y mantenimiento (o cambio de partes) que se desean destacar en el contenido de la documentación suministrada con los equipos.



Este símbolo se utiliza para advertir al usuario sobre la presencia de elementos con voltaje peligroso sin protección aislante, que puedan encontrarse dentro de la caja o alojamiento del producto, y que puedan representar riesgo de electrocución.

Precaución

Leer las instrucciones • Leer y analizar todas las instrucciones de operación y seguridad, antes de usar el equipo.

Conservar las instrucciones • Conservar las instrucciones de seguridad para futura consulta.

Obedecer las advertencias • Todas las advertencias e instrucciones marcadas en el equipo o en la documentación del usuario, deben ser obedecidas.

Evitar el uso de accesorios • No usar herramientas o accesorios que no sean específicamente recomendados por el fabricante, ya que podrían implicar riesgos.

Warning

Power sources • This equipment should be operated only from the power source indicated on the product. This equipment is intended to be used with a main power system with a grounded (neutral) conductor. The third (grounding) pin is a safety feature, do not attempt to bypass or disable it.

Power disconnection • To remove power from the equipment safely, remove all power cords from the rear of the equipment, or the desktop power module (if detachable), or from the power source receptacle (wall plug).

Power cord protection • Power cords should be routed so that they are not likely to be stepped on or pinched by items placed upon or against them.

Servicing • Refer all servicing to qualified service personnel. There are no user-serviceable parts inside. To prevent the risk of shock, do not attempt to service this equipment yourself because opening or removing covers may expose you to dangerous voltage or other hazards.

Slots and openings • If the equipment has slots or holes in the enclosure, these are provided to prevent overheating of sensitive components inside. These openings must never be blocked by other objects.

Lithium battery • There is a danger of explosion if battery is incorrectly replaced. Replace it only with the same or equivalent type recommended by the manufacturer. Dispose of used batteries according to the manufacturer's instructions.

Avvertimento

Alimentazioni • Ne fare funzionare ce matériel qu'avec la source d'alimentation indiquée sur l'appareil. Ce matériel doit être utilisé avec une alimentation principale comportant un fil de terre (neutre). Le troisième contact (de mise à la terre) constitue un dispositif de sécurité : n'essayez pas de le contourner ni de le désactiver.

Déconnexion de l'alimentation • Pour mettre le matériel hors tension sans danger, déconnectez tous les cordons d'alimentation de l'arrière de l'appareil ou du module d'alimentation de bureau (s'il est amovible) ou encore de la prise secteur.

Protection du cordon d'alimentation • Achémener les cordons d'alimentation de manière à ce que personne ne risque de marcher dessus et à ce qu'ils ne soient pas écrasés ou pincés par des objets.

Réparation-maintenance • Faire exécuter toutes les interventions de réparation-maintenance par un technicien qualifié. Aucun des éléments internes ne peut être réparé par l'utilisateur. Afin d'éviter tout danger d'électrocution, l'utilisateur ne doit pas essayer de procéder lui-même à des opérations car l'ouverture ou le retrait des couvercles risquent de l'exposer à de hautes tensions et autres dangers.

Fentes et orifices • Si le boîtier de l'appareil comporte des fentes ou des orifices, ceux-ci servent à empêcher les composants internes sensibles de surchauffer. Ces ouvertures ne doivent jamais être bloquées par des objets.

Lithium Batterie • Il y a danger d'explosion s'il y a remplacement incorrect de la batterie. Remplacer uniquement avec une batterie du même type ou d'un type équivalent recommandée par le constructeur. Mettre au rebut les batteries usagées conformément aux instructions du fabricant.

Vorsicht

Stromquellen • Dieses Gerät sollte nur über die auf dem Produkt angegebene Stromquelle betrieben werden. Dieses Gerät wurde für eine Verwendung mit einer Hauptstromleitung mit einem geerdeten (neutralen) Leiter konzipiert. Der dritte Kontakt ist für einen Erdschluß, und stellt eine Sicherheitsfunktion dar. Diese sollte nicht umgangen oder außer Betrieb gesetzt werden.

Stromunterbrechung • Um das Gerät auf sichere Weise vom Netz zu trennen, sollten Sie alle Netzkabel aus der Rückseite des Gerätes, aus der externen Stromversorgung (falls dies möglich ist) oder aus der Wandsteckdose ziehen.

Schutz des Netzkabels • Netzkabel sollten stets so verlegt werden, daß sie nicht im Weg liegen und niemand darauf treten kann oder Objekte darauf- oder unmittelbar dagegen gestellt werden können.

Wartung • Alle Wartungsmaßnahmen sollten nur von qualifiziertem Servicepersonal durchgeführt werden. Die internen Komponenten des Gerätes sind wartungsfrei. Zur Vermeidung eines elektrischen Schocks versuchen Sie in keinem Fall, dieses Gerät selbst öffnen, da beim Entfernen der Abdeckungen die Gefahr eines elektrischen Schlags und/oder andere Gefahren bestehen.

Schlitze und Öffnungen • Wenn das Gerät Schlitze oder Löcher im Gehäuse aufweist, dienen diese zur Vermeidung einer Überhitzung der empfindlichen Teile im Inneren. Diese Öffnungen dürfen niemals von anderen Objekten blockiert werden.

Lithium-Batterie • Explosionsgefahr, falls die Batterie nicht richtig ersetzt wird. Ersetzen Sie verbrauchte Batterien nur durch den gleichen oder einen vergleichbaren Batterietyp, der auch vom Hersteller empfohlen wird. Entsorgen Sie verbrauchte Batterien bitte gemäß den Herstelleranweisungen.

Advertencia

Alimentación eléctrica • Este equipo debe conectarse únicamente a la fuente/tipo de alimentación eléctrica indicada en el mismo. La alimentación eléctrica de este equipo debe provenir de un sistema de distribución general con conductor neutro a tierra. La tercera pata (puesta a tierra) es una medida de seguridad, no puentearla ni eliminarla.

Desconexión de alimentación eléctrica • Para desconectar con seguridad la acometida de alimentación eléctrica al equipo, desenchufar todos los cables de alimentación en el panel trasero del equipo, o desenchufar el módulo de alimentación (si fuera independiente), o desenchufar el cable del receptáculo de la pared.

Protección de los cables de alimentación • Los cables de alimentación eléctrica se deben instalar en lugares donde no sean pisados ni apretados por objetos que se puedan apoyar sobre ellos.

Reparaciones/mantenimiento • Solicitar siempre los servicios técnicos de personal calificado. En el interior no hay partes a las que el usuario debe acceder. Para evitar riesgo de electrocución, no intentar personalmente la reparación/mantenimiento de este equipo, ya que al abrir o extraer las tapas puede quedar expuesto a voltajes peligrosos u otros riesgos.

Ranuras y aberturas • Si el equipo posee ranuras o orificios en su caja/alojamiento, es para evitar el sobrecalentamiento de componentes internos sensibles. Estas aberturas nunca se deben obstruir con otros objetos.

Batería de litio • Existe riesgo de explosión si esta batería se coloca en la posición incorrecta. Cambiar esta batería únicamente con el mismo tipo (o su equivalente) recomendado por el fabricante. Deschar las baterías usadas siguiendo las instrucciones del fabricante.

Precautions

安全须知 • 中文



这个符号提示用户该设备用户手册中有重要的操作和维护说明。



这个符号警告用户该设备机壳内有暴露的危险电压，有触电危险。

注意

阅读说明书 • 用户使用该设备前必须阅读并理解所有安全和使用说明。

保存说明书 • 用户应保存安全说明书以备将来使用。

遵守警告 • 用户应遵守产品和用户指南上的所有安全和操作说明。

避免追加 • 不要使用该产品厂商没有推荐的工具或追加设备，以避免危险。

警告

电源 • 该设备只能使用产品上标明的电源。设备必须使用有地线的供电系统供电。第三条线（地线）是安全设施，不能不用或跳过。

拔掉电源 • 为安全地从设备拔掉电源，请拔掉所有设备后或桌面电源的电源线，或任何接到市电系统的电源线。

电源线保护 • 妥善布线，避免被踩踏，或重物挤压。

维护 • 所有维修必须由认证的维修人员进行。设备内部没有用户可以更换的零件。为避免出现触电危险不要自己试图打开设备盖子维修该设备。

通风孔 • 有些设备机壳上有通风槽或孔，它们是用来防止机内敏感元件过热。不要用任何东西挡住通风孔。

锂电池 • 不正确的更换电池会有爆炸的危险。必须使用与厂家推荐的相同或相近型号的电池。按照生产厂的建议处理废弃电池。

FCC Class A Notice

This equipment has been tested and found to comply with the limits for a Class A digital device, pursuant to part 15 of the FCC Rules. Operation is subject to the following two conditions: (1) this device may not cause harmful interference, and (2) this device must accept any interference received, including interference that may cause undesired operation. The Class A limits are designed to provide reasonable protection against harmful interference when the equipment is operated in a commercial environment. This equipment generates, uses, and can radiate radio frequency energy and, if not installed and used in accordance with the instruction manual, may cause harmful interference to radio communications. Operation of this equipment in a residential area is likely to cause harmful interference, in which case the user will be required to correct the interference at his own expense.

NOTE

This unit was tested with shielded cables on the peripheral devices. Shielded cables must be used with the unit to ensure compliance with FCC emissions limits.

Table of Contents

About this Guide	1
About the MTP 1500RL 15HD A Series of Receivers	1
TP cable advantages	2
Transmission distance	2
Application Diagram	3
Installation	4
UL guidelines for rack mounted devices	5
Rack mounting	5
Connections and Settings	6
Connector wiring	8
Power supply wiring	8
TP cable termination	10
Front Panel Controls and Indicators	10
Peaking and Level Adjustment	11
Skew Delay Compensation	12
SEQ receiver skew compensation	12
Non-SEQ receivers skew compensation	13
Specifications	14
Part Numbers	17
MTP receivers	17
Accessories	17
Enhanced Skew-Free™ A/V cable	17
RJ-45 connectors	17

All trademarks mentioned in this manual are the properties of their respective owners.

Introduction

About this Guide

This manual details the installation and operation of the Extron MTP 1500RL 15HD A series of Mini Twisted Pair receivers.

- 1500RL 15HD A SEQ mini twisted pair receiver with audio and skew equalization
- MTP 1500RL 15HD A mini twisted pair receiver with audio

In this manual the following terms are applicable:

- “transmitter” refers specifically to the MTP transmitter.
- “receiver” refers to any MTP 1500RL 15HD A model.
- “SEQ receiver” refers specifically to the MTP 1500RL 15HD A SEQ receivers with skew equalization.

About the MTP 1500RL 15HD A Series of Receivers

Extron MTP 1500RL 15HD A SEQ and MTP 1500RL 15HD A receivers are for long distance distribution of RGB, component (bi-/tri-level), S-video, or composite video signals and audio over twisted pair cables.

The Extron MTP 1500RL 15HD A series is a half rack size line of basic twisted pair receivers that are fully compatible with all MTP transmitters, distribution amplifiers, matrix switchers and associated video accessories. When used with any of the Extron MTP transmitter models, the video can be transmitted over an extended distance or over current standard distances.

The MTP 1500RL 15HD A models receive signals up to UXGA, HD component video (including 1080p), standard component, S-video, bi-level or tri-level component video, and high resolution RGB video) on an RJ-45 connector over Extron’s Enhanced Skew-Free™ A/V UTP cable, or over Category (CAT) 5 shielded twisted pair (STP), unshielded twisted pair (UTP), or foil shielded twisted pair (FTP) cable.

The receiver outputs multiple RGB formats, composite video, S-video and component video on the 15-pin HD connector, according to the current DIP switch settings.

NOTE *The MTP 1500RL series of receivers cannot be used with VTT or TP transmitters.*

The MTPs ship with external desktop 12 V, 1 A power supplies that accept 100 to 240 VAC, 50 Hz to 60 Hz input.

TP cable advantages

Twisted pair cable is much smaller, lighter, more flexible, and less expensive than coaxial cable. These TP products make cable runs simpler and less cumbersome, and termination with RJ-45 connectors is simple, quick, and economical.

Transmission distance

The maximum distance is determined by the frequency and resolution of the signal transmitted. The table below specifies the maximum transmission distances and transmitter Pre-peak switch positions using Extron Enhanced Skew-Free A/V UTP cable or UTP CAT cable, terminated with RJ-45 connectors.

Video format	Pre-peak off	Pre-peak on	Max distance (feet)
Vid, S-vid, YUV	<1300	>1400	1500
640x480	<1300	>1400	1500
800x600	<1300	>1400	1500
1024x768	<1300	>1400	1500
1280x960	<1300	>1400	1500
1280x1024	<1300	>1400	1500
1360x765	<1300	>1400	1500
1365x768	<1300	>1400	1500
1366x768	<1300	>1400	1500
1440x960	<1300	>1400	1500
1440x1050	<1300	>1400	1500
1600x1200	<1300	>1400	1500
1920x1200	<1000	>1100	1200
2048x1080	<1000	>1100	1200
720p	<1300	>1400	1500
1080i	<1300	>1400	1500
1080p	<1300	>1400	1500

NOTE *The transmitter and receiver are designed for and perform best with Extron Enhanced Skew-Free A/V cable terminated in accordance with the TIA/EIA T568A standard. CAT 5 cables are acceptable but less preferable. We also recommend the use of preterminated and tested cables. Cables terminated on site should be tested before use to ensure that they comply with Category 5 specifications.*

Application Diagram

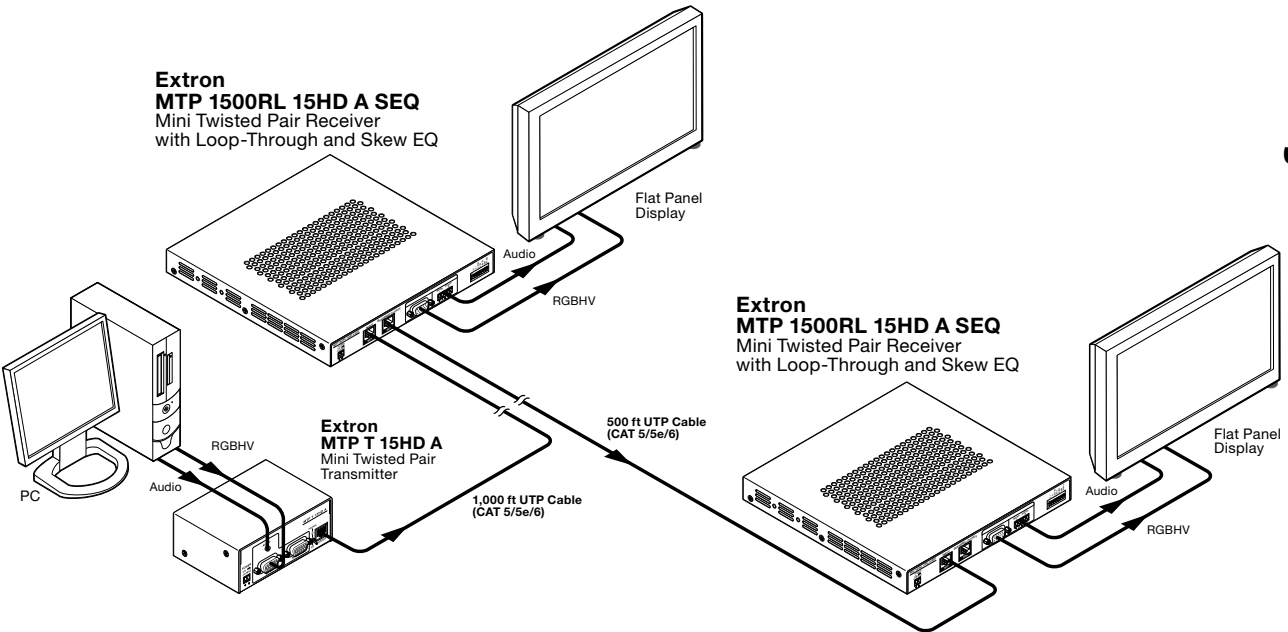

Figure 1 — Typical MTP 1500RL 15HD A SEQ application

Installation

Installation

CAUTION

Installation and service must be performed by authorized personnel only.

The 1U high, half rack width, MTP receiver can be mounted on a standard rack shelf.

UL guidelines for rack mounted devices

The following Underwriters Laboratories (UL) guidelines pertain to the safe installation of the MTP receiver in a rack.

1. **Elevated operating ambient temperature** — If installed in a closed or multi-unit rack assembly, the operating ambient temperature of the rack environment may be greater than room ambient temperature. Therefore, install the device in an environment compatible with the maximum ambient temperature ($T_{ma} = +122\text{ }^{\circ}\text{F}$, $+50\text{ }^{\circ}\text{C}$) specified by Extron.
2. **Reduced air flow** — Install the equipment in a rack so that the amount of air flow required for safe operation of the equipment is not compromised.
3. **Mechanical loading** — Mount the equipment in the rack so that a hazardous condition is not achieved due to uneven mechanical loading.
4. **Circuit overloading** — Connect the equipment to the supply circuit and consider the effect that circuit overloading might have on overcurrent protection and supply wiring. Appropriate consideration of equipment nameplate ratings should be used when addressing this concern.
5. **Reliable earthing (grounding)** — Maintain reliable grounding of rack-mounted equipment. Pay particular attention to supply connections other than direct connections to the branch circuit (e.g., use of power strips).

Installation, cont'd

Rack mounting

On the standard rack shelf, the MTP 1500RL receiver can be mounted in one of four locations to the rear of the rack or in one of four locations to the front of the rack.

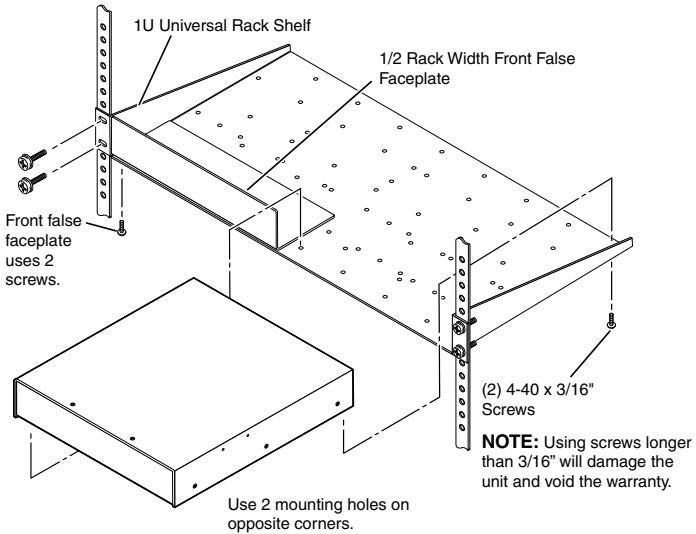

Figure 2 — Mounting the MTP on a standard shelf

1. Remove the feet from the bottom of the MTP, if they are installed.
2. Mount the MTP using two 4-40 x 3/16" screws in opposite (diagonal) corners to secure the MTP to the shelf.

NOTE *DO NOT stack units on top of one another as this may cause the units to overheat.*

3. Install false faceplate(s) or other unit(s) to the rack shelf.

Connections and Settings

Rear panel connectors and features for the MTP 1500RL A series of receivers are shown below.

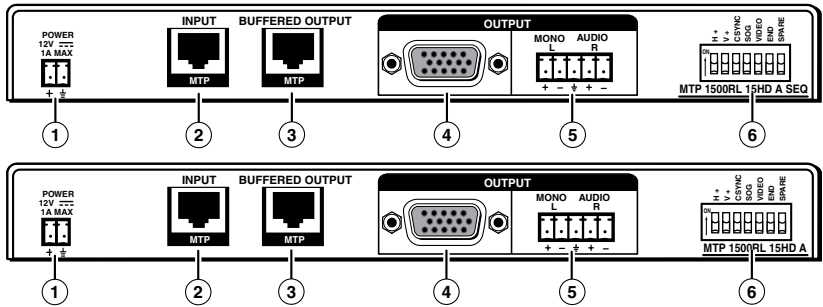

Figure 3 — Receivers' rear panel features

- ① **Power connector** — Plug the included external 12 VDC, 1 A, power supply into this 2-pole captive screw connector. See “Power supply wiring” on page 8 to wire the connector.
- ② **Signal input connector** — Connect one end of the twisted pair (TP) cable from an MTP transmitter. See “TP cable termination” on page 9 to wire the connectors.

CAUTION Do not connect these devices to a computer data or telecommunications network.
Minimum distance from the transmitter is 50 feet.

- ③ **Buffered output connector** — Connect up to 8 daisy-chained MTP receivers to this RJ-45 connector.
- ④ **High resolution video output connector** — Connect a projector or other high resolution video device to this 15-pin HD connector for RGB output.

NOTE See DIP switch settings for signal format output.

- ⑤ **Audio connector** — Connect a suitable audio device to the 5-pole captive screw connector for mono audio output.

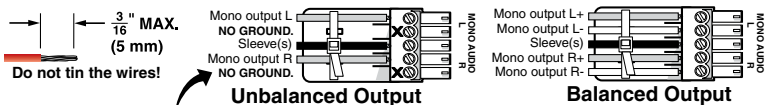

CAUTION

For unbalanced audio, connect the sleeve(s) to the center contact ground.
DO NOT connect the sleeve(s) to the negative (-) contacts.

Figure 4 — Audio connector wiring

Installation, cont'd

⑥ **Receiver DIP switches** — Set these DIP switches for the applicable signal.

- **H sync (H+) and V sync (V+) switches** — Set these switches up (ON) for positive sync or down for negative sync.

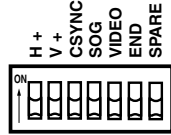

- **Composite sync (CSync), Sync on green (SOG), and Video switches** — Set these switches as shown in the table below to output the indicated format.

Output Format	C Sync	SOG	Video
RGBHV	▼	▼	▼
RGBS	▲	▼	▼
RGsB	▼	▲	▼
Component video*	▼	▼	▲
S-video	▼	▼	▲
Composite video*	▼	▼	▲
* Input video format must match. ▼ = switch is down, ▲ = switch is up			

- **End unit switch** — Set this End switch up if either of the following is true:
 - The receiver being configured is the only receiver connected to the transmitter.
 - The receiver being configured is the last receiver in a daisy-chained system.

Connector Wiring

Power supply wiring

NOTE This product is intended to be supplied by a UL Listed power supply and output rated at 12 VDC, 1 A.

Wire the supplied male power connector (plug) as in figure 5.

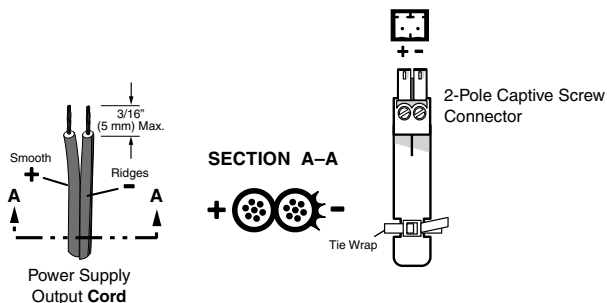

Figure 5 — Power connector wiring

CAUTION Power supply voltage polarity is critical. Incorrect voltage polarity can damage the power supply and the product. Identify the power cord negative lead by the ridges on the side of the cord.

NOTE The length of the exposed (stripped) copper wires is important. The ideal length is 3/16" (5 mm). Longer bare wires can short together. Shorter wires are not as secure in the captive screw connectors and could be pulled out.

Do not tin the stripped power supply leads before installing the captive screw connector. Tinned wires are not as secure in the captive screw connectors and could be pulled out.

To verify the polarity before connection, plug in the power supply with no load and check the output with a voltmeter.

WARNING The two power cord wires must be kept separate while the power supply is plugged in. Remove power before wiring.

As an alternative, an Extron PS 123 Universal 12 VDC Power Supply, part #60-814-01, can power multiple MTPs or other Extron 12 VDC devices using only one AC power connector.

Insert the wired plug into the power connector on the rear panel. Do not power on the device at this time.

Installation, cont'd

TP cable termination

NOTE RJ-45 termination must comply with TIA/EIA T568A or TIA/EIA T568B wiring standards for all connections.

Figure 10 details the recommended termination of TP cables with RJ-45 connectors in accordance with the TIA/EIA T568A or TIA/EIA T568B wiring standards. Either standard can be used with CAT 5 cable, but ensure that the same standard is used on both ends of the cable.

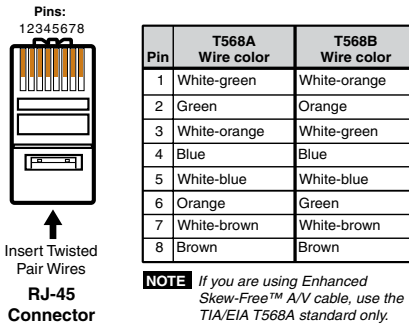

Figure 6 — TP cable termination

NOTE Enhanced Skew-free A/V cable is **not recommended** for Ethernet/LAN applications.

DO NOT connect the input RJ-45 to LAN, Ethernet, outside plant communications, or any telecommunications networks.

NOTE This cable is specially designed for compatibility with Extron's Twisted Pair products that are wired using the TIA/EIA T568A standard.

The table below shows the MTP RJ-45 pin assignments for audio and video signals.

Pin	RGBHV	RGBS	Composite	S-Video	Component
1	Red/V sync +	Red +	No Signal	Chroma +	R-Y +
2	Red/V sync -	Red -	No Signal	Chroma -	R-Y -
3	Mono Audio+	Mono Audio +	Mono Audio +	Mono Audio +	Mono Audio +
4	Green +	Green +	Video +	Luma +	Y +
5	Green -	Green -	Video -	Luma -	Y -
6	Mono Audio -	Mono Audio -	Mono Audio -	Mono Audio -	Mono Audio -
7	Blue/H Sync +	Blue/C Sync +	No Signal	No Signal	B-Y +
8	Blue/H Sync -	Blue/C Sync -	No Signal	No Signal	B- Y -

Front Panel Controls and Indicators

Front panel features on the MTP 1500RL 15HD A series receivers are shown below.

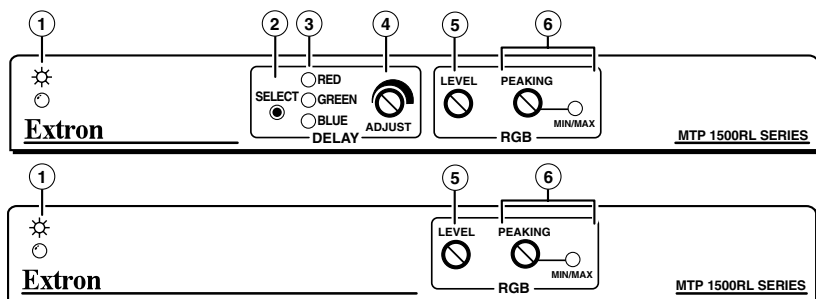

Figure 7 — MTP receiver series front panels

- ① **Power LED** — Indicates power is applied to the MTP.
- ② **Select button (SEQ models only)** — This recessed button selects the red, green, or blue video signal to adjust and resets all three video signals to a skew delay of zero nanoseconds. Use a Tweezer to press and release this button to cycle and select the red, green, or blue video signal to adjust. The selected signal is indicated by the Red, Green, and Blue LEDs (③).

NOTE *The SEQ receiver automatically saves the setting for the video signal that is being deselected when this button is pushed or when the selection times out after 10 seconds.*

*Press and **hold** the button in for approximately 3 seconds to zero the skew delay for red, green, and blue. The Red, Green, and Blue LEDs (④) all turn off. Release the button.*

- ③ **R(ed), G(reen), and B(lue) LEDs (SEQ models only)** — These indicate the video signal that is selected by the Select button (②) for skew adjustment using the Adjust control (④). The LED for the selected color flashes when the skew compensation for that color's video signal has reached the minimum or maximum limit.
- ④ **Adjust skew control (SEQ models only)** — This control delays the selected red, green, or blue video signal by up to a maximum of 62 nanoseconds (ns), in 2 ns incremental steps. Rotate the control counterclockwise to reduce the delay or clockwise to increase the delay. See "Skew Delay Compensation" for details.

Installation, cont'd

NOTE *The Adjust control's movement is smooth; it does not have mechanical steps or high- and low-limit stops.*

Watch the displayed image to observe the steps of delay.

For best performance the skew of the most delayed signal should be set to 0 ns (min.) and the other two signals adjusted to meet it.

- ⑤ **Level control** — The Level control alters the video output voltage to affect the brightness of the displayed image. Adjust the knob while viewing the displayed image to set the level/boost that provides the best picture quality. See the “Peaking and Level Adjustment” section for details.
- ⑥ **Peaking control** — Peaking affects the sharpness of a picture. Increased peaking can compensate for mid- and high-frequency detail loss from low bandwidth system components or capacitance in long cables.

Adjust this control while viewing the displayed image to obtain the optimum picture sharpness. The LED lights red when at the minimum (zero) and maximum (100%) peaking settings. See the “Peaking and Level Adjustment” section for details.

NOTE *To avoid possible video loss due to errors in the format detection, the user should always start with minimal peaking and level, then only increase values as required.*

Peaking and Level Adjustment

For best performance and video format detection, the equalization of the MTP should be adjusted properly.

To achieve this do the following:

1. Terminate the **green** video signal output with a 75 ohm resistance, and measure the video signal.

NOTE *Gain adjustment should be set so that a white field video signal is +0.7 volts from the ground level.*

Peaking adjustment should be set using the highest frequency video format signal for the system in RGB, component video, or S-video.

2. Using an alternative black/white pattern, adjust the peaking so that the video signal matches that of the white field video. This equalizes both the low frequency (white field) and the high frequency (alternating black/white field) to the same video level for best results.

Do not over-peak the signal.

Skew Delay Compensation

CAT cable can lead to registration errors between the red, green, and blue video signals. Pair skew can be measured with test equipment or identified by viewing a crosshatch test pattern with a critical eye to determine if either the red, green, or blue video image leads (appears to the left of) the other two video images.

NOTE *Unless the TP cable is changed, the skew adjustment should only need to be made once, during installation.*

SEQ receiver skew compensation

The SEQ receivers have built-in skew compensation capabilities. Adjust the equalization as follows:

1. **Zero the skew delay** for red, green, and blue as follows:
 - a. Use a Tweaker or other small screwdriver to press and **hold** the Select button for 3 seconds. The Red, Green, and Blue LEDs all go out.
 - b. Release the Select button.
2. Use UTP cable test equipment or examine the displayed video image with a critical eye to **determine which video signal**, red, green, or blue, is **shifted furthest to the right**.

NOTE *A crosshatch test pattern or a black background with vertical white lines is ideal for determining skew.*

3. **Adjust the furthest left video signal** as follows:

NOTE *The SEQ receiver cannot shift the furthest right video image to the left.*

- a. Use a Tweaker or other small screwdriver to press and release the Select button until the LED for the left-shifted color (red, green, or blue) lights.
- b. *Slowly* rotate the Adjust control clockwise while monitoring the display. Continue to rotate the control until that color is properly converged.

NOTE *A 2-nanosecond (ns) adjustment is very fine. Up to 10 ns of delay may be necessary before a change in the display is detectable. Maximum delay possible is 62 nanoseconds.*

- c. Use a Tweaker or other small screwdriver to press the Select button one more time to save the most recent adjustment or allow the 10-second timeout to elapse.
4. If the remaining color is left shifted, repeat step 3.

Installation, cont'd

Non-SEQ receivers skew compensation

Try using the following methods to minimize or eliminate pair skew:

- Switch to Extron's Enhanced Skew-Free A/V UTP cable.
- Add a skew compensation cable equal to the length of pair skew to the receiver's output.
- Install an SEQ 100 15HD Skew Equalizer on the receiver's video output and adjust the skew for the leading video image.

Specifications

Video

Gain.....	Unity
Number/signal type.....	1 set of proprietary analog signals
Connectors	1 female RJ-45

Video input — see MTP Series transmitters' specs.

Video output — receivers

Number/signal type.....	1 set of proprietary analog signals 1 analog RGBHV, RGBS, RGsB, RsGsBs, component video (bi-/tri-level sync), S-video, or composite video
Connectors	1 female RJ-45 1 female 15-pin HD
Nominal level	1 V p-p for Y of component video and S-video, and for composite video 0.7 V p-p for RGB and for R-Y and B-Y of component video 0.3 V p-p for C of S-video
Minimum/maximum levels.....	0.3 V to 1.45 V p-p
Impedance.....	75 ohms
Return loss.....	<-30 dB @ 5 MHz
DC offset.....	<±35 mV with input at 0 offset
Skew compensation	62 ns
Maximum resolution	Up to 1600x1200 and 1080p at 1500', 1920x1200 and 2048x1080 at 1200'.

Sync

Output type.....	RGBHV, RGBS, RGsB, RsGsBs
Standards.....	NTSC 3.58, NTSC 4.43, PAL, SECAM
Output level	0.3 Vp-p for component video (bi-level sync) 0.6 Vp-p for component video (tri-level sync) TTL: 4.0 V to 5.0 V p-p, unterminated for RGBHV, RGBS
Output impedance	110 ohms
Polarity.....	Positive or negative (switch-selectable)

Specifications, cont'd

Audio — MTP 1500RL 15HD A, MTP 1500RL 15HD A SEQ

Number/signal type.....	1 set of proprietary analog signals
Connectors	1 female RJ-45
Gain	Unbalanced output: 0 dB; balanced output: +6 dB
Frequency response	20 Hz to 20 kHz, ± 1 dB
THD + Noise.....	0.15% @ 1 kHz, 0.3% @ 20 kHz at nominal level
S/N.....	>70 dB at maximum output (unweighted)
CMRR.....	>43 dB @ 20 Hz to 20 kHz

Audio input — See MTP Series transmitters' specs

NOTE $0 \text{ dBu} = 0.775 \text{ Vrms}$, $0 \text{ dBV} = 1 \text{ Vrms}$, $0 \text{ dBV} \approx 2 \text{ dBu}$

Audio output — MTP 1500RL 15HD A, MTP 1500RL 15HD A SEQ

Number/signal type.....	2 mono, balanced/unbalanced
Connectors	(1) 3.5 mm captive screw connector, 5 pole
Impedance.....	50 ohms unbalanced, 100 ohms balanced
Nominal level	+4 dBu (1.23 Vrms), -10 dBV (316 mVrms)
Maximum level.....	+18 dBu, unbalanced at 1% THD+N

General

Recommended cable type.....	CAT 5/5E/6 (shielded or unshielded)
External power supply	100 VAC to 240 VAC, 50-60 Hz, external; to 12 VDC, 1 A, regulated
Power input requirements	12 VDC, 1.0 A max.
Temperature/humidity.....	Storage: -40 to +158 °F (-40 to +70 °C) / 10% to 90%, noncondensing Operating: +32 to +122 °F (0 to +50 °C) / 10% to 90%, noncondensing
Cooling	Convection, vents sides to top
Mounting	
Rack mount.....	Yes, with optional 1U, 9.5" deep rack shelf
Wall mount.....	Wall mountable with optional wall mounting kit
Enclosure type	Metal
Enclosure dimensions.....	1.0" H x 8.75" W x 6.0" D (half rack wide) (2.5 cm H x 22.2 cm W x 15.2 cm D) (Depth excludes connectors.)
Product weight	1 lb (0.5 kg)

Shipping weight	2 lbs (1 kg)
Vibration	ISTA 1A in carton (International Safe Transit Association)
Regulatory compliance	
Safety	CE, c-UL, UL
EMI/EMC	CE, C-tick, FCC Class A, ICES, VCCI
MTBF	30,000 hours
Warranty	3 years parts and labor

NOTE *All nominal levels are at $\pm 10\%$.*

NOTE *Specifications are subject to change without notice.*

Specifications, cont'd

Part Numbers

Item	Part number
MTP Receivers	
MTP 1500RL 15HD A SEQ receiver	60-959-02
MTP 1500RL 15HD A receiver	60-959-01
Accessories	
PS 123 multiple output 12 V power supply	60-814-01
19" 1U Universal Rack Shelf	60-190-01
19" 1U Basic Rack Shelf	60-604-01
Enhanced Skew-Free™ A/V cable	
NOTE <i>Enhanced Skew-Free™ A/V UTP cables are not recommended for Ethernet/LAN applications.</i>	
Enhanced Skew-Free A/V cable (cut, various lengths)	26-569-xx
Enhanced Skew-Free A/V 1000' (Bulk) (non-plenum)	22-141-03
Plenum enhanced Skew-Free A/V 1000' (Bulk)	22-142-03
RJ-45 connectors	
CAT 6 jack (black)	10-463-10
CAT 6 jack (red)	10-463-11
CAT 6 jack (blue)	10-463-12
CAT 6 jack (orange)	10-463-13
CAT 6 jack (gray)	10-463-14
CAT 6 jack (white)	10-463-15
CAT 6 jack (ivory)	10-463-16

Extron's Warranty

Extron Electronics warrants this product against defects in materials and workmanship for a period of three years from the date of purchase. In the event of malfunction during the warranty period attributable directly to faulty workmanship and/or materials, Extron Electronics will, at its option, repair or replace said products or components, to whatever extent it shall deem necessary to restore said product to proper operating condition, provided that it is returned within the warranty period, with proof of purchase and description of malfunction to:

**USA, Canada, South America,
and Central America:**

Extron USA
1001 East Ball Road
Anaheim, CA 92805
U.S.A.

Europe, Africa, and the Middle East:

Extron Europe
Hanzeboulevard 10
3825 PH Amersfoort
The Netherlands

Asia:

Extron Asia
135 Joo Seng Road #04-01
PM Industrial Bldg.
Singapore 368363
Singapore

Japan:

Extron Japan
Kyodo Building, 16 Ichibancho
Chiyoda-ku, Tokyo 102-0082
Japan

China:

Extron China
686 Ronghua Road,
Songjiang District
Shanghai 201611
China

Middle East:

Extron Middle East
Dubai Airport Free Zone
F12, PO Box 293666
United Arab Emirates, Dubai

This Limited Warranty does not apply if the fault has been caused by misuse, improper handling care, electrical or mechanical abuse, abnormal operating conditions or non-Extron authorized modification to the product.

If it has been determined that the product is defective, please call Extron and ask for an Applications Engineer at (714) 491-1500 (USA), 31.33.453.4040 (Europe), 65.6383.4400 (Asia), or 81.3.3511.7655 (Japan) to receive an RA# (Return Authorization number). This will begin the repair process as quickly as possible.

Units must be returned insured, with shipping charges prepaid. If not insured, you assume the risk of loss or damage during shipment. Returned units must include the serial number and a description of the problem, as well as the name of the person to contact in case there are any questions.

Extron Electronics makes no further warranties either expressed or implied with respect to the product and its quality, performance, merchantability, or fitness for any particular use. In no event will Extron Electronics be liable for direct, indirect, or consequential damages resulting from any defect in this product even if Extron Electronics has been advised of such damage.

Please note that laws vary from state to state and country to country, and that some provisions of this warranty may not apply to you.

Extron USA - West
Headquarters

+800.633.9876
Inside USA / Canada Only
+1.714.491.1500
+1.714.491.1517 FAX

Extron USA - East

+800.633.9876
Inside USA / Canada Only
+1.919.863.1794
+1.919.863.1797 FAX

Extron Europe

+800.3987.6673
Inside Europe Only
+31.33.453.4040
+31.33.453.4050 FAX

Extron Asia

+800.7339.8766
Inside Asia Only
+65.6383.4400
+65.6383.4664 FAX

Extron Japan

+81.3.3511.7655
+81.3.3511.7656 FAX

Extron China

+400.853.1568
Inside China Only
+86.21.3760.1568
+86.21.3760.1566 FAX

Extron Middle East

+971.4.2991800
+971.4.2991880 FAX