

User's Manual



MTP 15HD A Series High Resolution Video and Audio MTP Transmitters and Receivers

Precautions

Safety Instructions • English



This symbol is intended to alert the user of important operating and maintenance (servicing) instructions in the literature provided with the equipment.



This symbol is intended to alert the user of the presence of uninsulated dangerous voltage within the product's enclosure that may present a risk of electric shock.

Caution

Read Instructions • Read and understand all safety and operating instructions before using the equipment.

Retain Instructions • The safety instructions should be kept for future reference.

Follow Warnings • Follow all warnings and instructions marked on the equipment or in the user information.

Avoid Attachments • Do not use tools or attachments that are not recommended by the equipment manufacturer because they may be hazardous.

Consignes de Sécurité • Français



Ce symbole sert à avertir l'utilisateur que la documentation fournie avec le matériel contient des instructions importantes concernant l'exploitation et la maintenance (réparation).



Ce symbole sert à avertir l'utilisateur de la présence dans le boîtier de l'appareil de tensions dangereuses non isolées posant des risques d'électrocution.

Attention

Lire les instructions • Prendre connaissance de toutes les consignes de sécurité et d'exploitation avant d'utiliser le matériel.

Conservier les instructions • Ranger les consignes de sécurité afin de pouvoir les consulter à l'avenir.

Respecter les avertissements • Observer tous les avertissements et consignes marqués sur le matériel ou présents dans la documentation utilisateur.

Éviter les pièces de fixation • Ne pas utiliser de pièces de fixation ni d'outils non recommandés par le fabricant du matériel car cela risquerait de poser certains dangers.

Sicherheitsanleitungen • Deutsch



Dieses Symbol soll dem Benutzer in der im Lieferumfang enthaltenen Dokumentation besonders wichtige Hinweise zur Bedienung und Wartung (Instandhaltung) geben.



Dieses Symbol soll den Benutzer darauf aufmerksam machen, daß im Inneren des Gehäuses dieses Produktes gefährliche Spannungen, die nicht isoliert sind und die einen elektrischen Schock verursachen können, herrschen.

Achtung

Lesen der Anleitungen • Bevor Sie das Gerät zum ersten Mal verwenden, sollten Sie alle Sicherheits- und Bedienungsanleitungen genau durchlesen und verstehen.

Aufbewahren der Anleitungen • Die Hinweise zur elektrischen Sicherheit des Produktes sollten Sie aufbewahren, damit Sie im Bedarfsfall darauf zurückgreifen können.

Befolgen der Warnhinweise • Befolgen Sie alle Warnhinweise und Anleitungen auf dem Gerät oder in der Benutzerdokumentation.

Keine Zusatzgeräte • Verwenden Sie keine Werkzeuge oder Zusatzgeräte, die nicht ausdrücklich vom Hersteller empfohlen wurden, da diese eine Gefahrenquelle darstellen können.

Instrucciones de seguridad • Español



Este símbolo se utiliza para advertir al usuario sobre instrucciones importantes de operación y mantenimiento (o cambio de partes) que se desean destacar en el contenido de la documentación suministrada con los equipos.



Este símbolo se utiliza para advertir al usuario sobre la presencia de elementos con voltaje peligroso sin protección aislante, que puedan encontrarse dentro de la caja o alojamiento del producto, y que puedan representar riesgo de electrocución.

Precaución

Leer las instrucciones • Leer y analizar todas las instrucciones de operación y seguridad, antes de usar el equipo.

Conservar las instrucciones • Conservar las instrucciones de seguridad para futura consulta.

Obedecer las advertencias • Todas las advertencias e instrucciones maradas en el equipo o en la documentación del usuario, deben ser obedecidas.

Evitar el uso de accesorios • No usar herramientas o accesorios que no sean específicamente recomendados por el fabricante, ya que podrían implicar riesgos.

Warning

Power sources • This equipment should be operated only from the power source indicated on the product. This equipment is intended to be used with a main power system with a grounded (neutral) conductor. The third (grounding) pin is a safety feature, do not attempt to bypass or disable it.

Power disconnection • To remove power from the equipment safely, remove all power cords from the rear of the equipment, or the desktop power module (if detachable), or from the power source receptacle (wall plug).

Power cord protection • Power cords should be routed so that they are not likely to be stepped on or pinched by items placed upon or against them.

Servicing • Refer all servicing to qualified service personnel. There are no user-serviceable parts inside. To prevent the risk of shock, do not attempt to service this equipment yourself because opening or removing covers may expose you to dangerous voltage or other hazards.

Slots and openings • If the equipment has slots or holes in the enclosure, these are provided to prevent overheating of sensitive components inside. These openings must never be blocked by other objects.

Lithium battery • There is a danger of explosion if battery is incorrectly replaced. Replace it only with the same or equivalent type recommended by the manufacturer. Dispose of used batteries according to the manufacturer's instructions.

Avvertimento

Alimentazione • Non fare funzionare ce matériel qu'avec la source d'alimentation indiquée sur l'appareil. Ce matériel doit être utilisé avec une alimentation principale comportant un fil de terre (neutre). Le troisième contact (de mise à la terre) constitue un dispositif de sécurité: n'essayez pas de la contourner ni de la désactiver.

Déconnexion de l'alimentation • Pour mettre le matériel hors tension sans danger, déconnectez tous les cordons d'alimentation de l'arrière de l'appareil ou du module d'alimentation de bureau (s'il est amovible) ou encore de la prise secteur.

Protection du cordon d'alimentation • Achémener les cordons d'alimentation de manière à ce que personne ne risque de marcher dessus et à ce qu'ils ne soient pas écrasés ou pincés par des objets.

Réparation-maintenance • Faire exécuter toutes les interventions de réparation-maintenance par un technicien qualifié. Aucun des éléments internes ne peut être réparé par l'utilisateur. Afin d'éviter tout danger d'électrocution, l'utilisateur ne doit pas essayer de procéder lui-même à ces opérations car l'ouverture ou le retrait des couvercles risquent de l'exposer à de hautes tensions et autres dangers.

Fentes et orifices • Si le boîtier de l'appareil comporte des fentes ou des orifices, ceux-ci servent à empêcher les composants internes sensibles de surchauffer. Ces ouvertures ne doivent jamais être bloquées par des objets.

Lithium Batterie • Il a danger d'explosion s'il y a un remplacement incorrect de la batterie. Remplacer uniquement avec une batterie du même type ou d'un équivalent recommandé par le constructeur. Mettre au rebut les batteries usagées conformément aux instructions du fabricant.

Vorsicht

Stromquellen • Dieses Gerät sollte nur über die auf dem Produkt angegebene Stromquelle betrieben werden. Dieses Gerät wurde für eine Verwendung mit einer Hauptstromleitung mit einem geerdeten (neutralen) Leiter konzipiert. Der dritte Kontakt ist für einen Erdschluß, und stellt eine Sicherheitsfunktion dar. Diese sollte nicht umgangen oder außer Betrieb gesetzt werden.

Stromunterbrechung • Um das Gerät auf sichere Weise vom Netz zu trennen, sollten Sie alle Netzkabel aus der Rückseite des Gerätes, aus der externen Stromversorgung (falls dies möglich ist) oder aus der Wandsteckdose ziehen.

Schutz des Netzkabels • Netzkabel sollten stets so verlegt werden, daß sie nicht im Weg liegen und niemand darauf treten kann oder Objekte darauf- oder unmittelbar dagegen gestellt werden können.

Wartung • Alle Wartungsmaßnahmen sollten nur von qualifiziertem Servicepersonal durchgeführt werden. Die internen Komponenten des Gerätes sind wartungsfrei. Zur Vermeidung eines elektrischen Schocks versuchen Sie in keinem Fall, dieses Gerät selbst öffnen, da beim Entfernen der Abdeckungen die Gefahr eines elektrischen Schlags und/oder anderer Gefahren bestehen.

Schlitze und Öffnungen • Wenn das Gerät Schlitze oder Löcher im Gehäuse aufweist, dienen diese zur Vermeidung einer Überhitzung der empfindlichen Teile im Inneren. Diese Öffnungen dürfen niemals von anderen Objekten blockiert werden.

Lithium-Batterie • Explosionsgefahr, falls die Batterie nicht richtig ersetzt wird. Ersetzen Sie verbrauchte Batterien nur durch den gleichen oder einen vergleichbaren Batterietyp, der auch vom Hersteller empfohlen wird. Entsorgen Sie verbrauchte Batterien bitte gemäß den Herstelleranweisungen.

Advertencia

Alimentación eléctrica • Este equipo debe conectarse únicamente a la fuente/tipo de alimentación eléctrica indicada en el mismo. La alimentación eléctrica de este equipo debe provenir de un sistema de distribución general con conductor neutro a tierra. La tercera pata (puesta a tierra) es una medida de seguridad, no puentearla ni eliminarla.

Desconexión de alimentación eléctrica • Para desconectar con seguridad la conectada de alimentación eléctrica al equipo, desenchufar todos los cables de alimentación en el panel trasero del equipo, o desenchufar el módulo de alimentación (si fuera independiente), o desenchufar el cable del receptáculo de la pared.

Protección del cables de alimentación • Los cables de alimentación eléctrica se deben instalar en lugares donde no sean pisados ni apretados por objetos que se puedan apoyar sobre ellos.

Reparaciones/mantenimiento • Solicitar siempre los servicios técnicos de personal calificado. En el interior no hay partes a las que el usuario debe acceder. Para evitar riesgo de electrocución, no intentar personalmente la reparación/mantenimiento de este equipo, ya que al abrir o extraer las tapas puede quedar expuesto a voltajes peligrosos u otros riesgos.

Ranuras y aberturas • Si el equipo posee ranuras o orificios en su caja/alojamiento, es para evitar el sobrecalentamiento de componentes internos sensibles. Estas aberturas nunca se deben obstruir con otros objetos.

Batería de litio • Existe riesgo de explosión si esta batería se coloca en la posición incorrecta. Cambiar esta batería únicamente con el mismo tipo (o su equivalente) recomendado por el fabricante. Desachar las baterías usadas siguiendo las instrucciones del fabricante.

安全须知 • 中文



这个符号提示用户该设备用户手册中有重要的操作和维护说明。



这个符号警告用户该设备机壳内有暴露的危险电压，有触电危险。

注意

阅读说明书 • 用户使用该设备前必须阅读并理解所有安全和使用说明。

保存说明书 • 用户应保存安全说明书以备将来使用。

遵守警告 • 用户应遵守产品和用户指南上的所有安全和操作说明。

避免追加 • 不要使用该产品厂商没有推荐的工具或追加设备，以避免危险。

警告

电源 • 该设备只能使用产品上标明的电源。设备必须使用有地线的供电系统供电。第三条线（地线）是安全设施，不能不用或跳过。

拔掉电源 • 为安全地从设备拔掉电源，请拔掉所有设备后或桌面电源的电源线，或任何接到市电系统的电源线。

电源线保护 • 妥善布线，避免被踩踏，或重物挤压。

维护 • 所有维修必须由认证的维修人员进行。设备内部没有用户可以更换的零件。为避免出现触电危险不要自己试图打开设备盖子维修该设备。

通风孔 • 有些设备机壳上有通风槽或孔，它们是用来防止机内敏感元件过热。不要用任何东西挡住通风孔。

锂电池 • 不正确的更换电池会有爆炸的危险。必须使用与厂家推荐的相同或相近型号的电池。按照生产厂的建议处理废弃电池。

FCC Class A Notice

This equipment has been tested and found to comply with the limits for a Class A digital device, pursuant to part 15 of the FCC Rules. Operation is subject to the following two conditions: (1) this device may not cause harmful interference, and (2) this device must accept any interference received, including interference that may cause undesired operation. The Class A limits are designed to provide reasonable protection against harmful interference when the equipment is operated in a commercial environment. This equipment generates, uses, and can radiate radio frequency energy and, if not installed and used in accordance with the instruction manual, may cause harmful interference to radio communications. Operation of this equipment in a residential area is likely to cause harmful interference, in which case the user will be required to correct the interference at his own expense.

NOTE

This unit was tested with shielded cables on the peripheral devices. Shielded cables must be used with the unit to ensure compliance with FCC emissions limits.

Table of Contents

About this Manual	1
About the MTP Transmitters and Receivers	1
Twisted pair (TP) cable advantages.....	3
Transmission distance.....	3
Installation	5
Rack mounting.....	5
UL guidelines	5
Rack mounting instructions	6
Back of the rack mounting instructions	8
Furniture or projector mounting	9
Connections and Settings	11
Transmitter	11
Power connection	11
Video and audio connections.....	11
Twisted pair connection and settings	12
Receiver	13
Power connection	13
Twisted pair connections.....	13
Video and audio connections and settings	14
Power supply wiring	16
TP cable termination	17
Front Panel Controls and Indicators	19
Skew Delay Compensation	21
SEQ receiver skew compensation	21
Non-SEQ receiver skew compensation	22
Specifications	23
Part Numbers	26
MTP transmitter and receivers for non-CAT 7 cable	26
MTP transmitter and receivers for CAT 7 cable	26
Included parts	26
Accessories	26
Cables/connectors	27

All trademarks mentioned in this manual are the properties of their respective owners.

Introduction

About this Manual

This manual documents two families of Extron MTP transmitters and receivers:

- **MTP products** that are compatible with:
 - Extron Enhanced Skew-Free™ A/V UTP cable
 - Category (CAT) 5, 5e, and 6 shielded twisted pair (STP), unshielded twisted pair (UTP), or foil shielded twisted pair (FTP) cable.
- **MTP C7 [CAT 7, C7] products** that are compatible with Digital Twisted Pair 26 (DTP26) or CAT 7 cable **only**.

In this manual, any reference to these products refers to either family, unless explicitly stated.

NOTE *For clarity and where applicable, in this manual, the CAT 5, 5e, 6 versions are referred to as non-C7 MTPs.*

This manual details the installation and operation of the following products:

- MTP T 15HD A twisted pair (TP) transmitter
- MTP RL 15HD A receiver with loop-through
- MTP RL 15HD A SEQ receiver with loop-through and skew equalization

In this manual:

- The term “transmitter” refers specifically to the MTP T 15HD A transmitter.
- The term “receiver” refers to either of the receiver models — the MTP RL 15HD A or MTP RL 15HD A SEQ.
- The term “SEQ receiver” refers specifically to the MTP RL 15HD A SEQ receiver with skew equalization capabilities.

About the MTP Transmitters and Receivers

The Extron MTP T 15HD A transmitter and MTP RL 15HD A and MTP RL 15HD A SEQ receivers are a system for long-distance distribution of VGA or other high resolution video and audio.

The MTPs are a part of the Extron compact line of basic distribution amplifiers, switches, transmitters and receivers, and associated video accessories.

High resolution video on a 15-pin HD connector as well as stereo audio on a 3.5 mm stereo jack is sent to the MTP transmitter. The transmitter sums the left and right audio channels to convert the audio to mono (L+R) format. The MTP T then converts the input video and mono audio signals to proprietary signals and outputs them to the compatible MTP receiver on an RJ-45 connector. A pre-peaking control allows you to boost the transmission distance of the proprietary signal. The transmitter also makes the input video available for local use on a 15-pin HD connector.

The transmitted proprietary signal is sent to the receiver on an RJ-45 connector and converts the signal back into its high resolution video and mono audio components. The receiver outputs the video on a 15-pin HD connector and the two sets of identical mono audio signals on a single 3.5 mm captive screw connector.

The receiver also buffers the proprietary input signal and sends it to another compatible MTP receiver or to a daisy chain of receivers.

NOTE *The transmitter provides pre-peaking, which boosts the signal before it is transmitted. The buffered output on the receiver does not provide any pre-peaking control. The total recommended distance (see table on page 4) for an entire daisy chain is the same as for a single transmitter and receiver. The Pre-Peak switch on the transmitter has the same affect on the recommended transmission distance for a daisy chain as for a single transmitter and receiver.*

NOTE *Up to eight receivers can be connected in series using Buffered Output connectors, provided that the total distance from the TP output of the transmitter to the last receiver in the chain does not exceed the recommended distance for the resolution being used.*

The SEQ receiver also corrects the skew delay (misconvergence) commonly encountered when CAT 5, 5e, 6, or 7 cables are used for RGB video, component video, and S-video transmission.

NOTE *An SEQ receiver should not be necessary when Extron Enhanced Skew-Free A/V UTP cable is used.*

Each MTP transmitter and receiver model is shipped with an external desktop 12 V power supply that accepts 100 VAC to 240 VAC, 50-60 Hz input.

Twisted pair (TP) cable advantages

Twisted pair cable is smaller, lighter, more flexible, and less expensive than coaxial cable. Termination of the cable with RJ-45 connectors is simple, quick, and economical.

Transmission distance

The maximum distance is determined by the frequency and resolution of the signal that is input to the transmitter. The [table on page 4](#) specifies the recommended maximum transmission distances and transmitter Pre-Peak switch positions ([see item ⑤](#) on page 12) using Extron Enhanced Skew-Free A/V UTP cable, DTP26 cable, or CAT 5, 5e, 6, or 7 cable, terminated with RJ-45 connectors.

NOTE *The non-C7 transmitter and receiver are designed for and perform best with Extron Enhanced Skew-Free A/V cable terminated in accordance with the TIA/EIA T 568 A wiring standard. CAT 5, 5e, and 6 cables are acceptable for the non-C7 models, but less preferable. We also recommend the use of preterminated and tested cables. Cables terminated on site should be tested before use to ensure that they comply with Category 5 specifications.*

NOTE *The use of DTP26 or CAT 7 cable with non-C7 products has a negative effect on transmission distance. DTP26 or CAT 7 cable should only be used with C7 products.*

NOTE *The recommendations shown in the [table on page 4](#) apply for a single transmitter and receiver and for a daisy chain. For example, the maximum suggested range for 1024 x 768 video is 300 feet (90 m) with the Pre-Peak switch off and 500 feet (150 m) with the Pre-Peak switch on, whether the system consists of one transmitter and one receiver or a transmitter and three daisy-chained receivers.*

NOTE *For daisy-chained units, the first receiver in the chain must be at least 100 feet (30 m) from the transmitter when the Pre-Peak switch is on.*

NOTE *For daisy-chained units, any receiver in the chain closer than 350 feet (105 m) may experience some form of overpeaking when the Pre-Peak switch is on. An overpeaked image may appear bloomed.*

Recommended Pre-Peak switch positions and transmission distances at 60 Hz

Video Format	Pre-Peak off	Pre-Peak on	Max. distance (high quality)	Max. distance (variable quality)
Composite, S-video, Component			800' (245 m)	1000' (300 m)
640 x 480	<300' (90 m)	>350' (105 m)	700' (215 m)	750' (240 m)
800 x 600	<300' (90 m)	>350' (105 m)	550' (165 m)	650' (200 m)
1024 x 768*	<300' (90 m)	>350' (105 m)	500' (150 m)	600' (185 m)
1280 x 960*	<300' (90 m)	>350' (105 m)	400' (120 m)	500' (150 m)
1280 x 1024*	<250' (75 m)	>300' (90 m)	350' (105 m)	450' (135 m)
1360 x 765	<250' (75 m)	>300' (90 m)	400' (120 m)	500' (150 m)
1365 x 768	<250' (75 m)	>300' (90 m)	400' (120 m)	450' (135 m)
1366 x 768	<250' (75 m)	>300' (90 m)	400' (120 m)	450' (135 m)
1400 x 1050	<250' (75 m)	>300' (90 m)	350' (105 m)	400' (120 m)
1440 x 900	<250' (75 m)	>300' (90 m)	350' (105 m)	400' (120 m)
1600 x 1200*	<250' (75 m)	>300' (90 m)	300' (90 m)	450' (135 m)
1920 x 1200	<250' (75 m)	>300' (90 m)	300' (90 m)	400' (120 m)
2048 x 1080	<250' (75 m)	>300' (90 m)	300' (90 m)	400' (120 m)
HDTV 720p	<250' (75 m)	>300' (90 m)	400' (120 m)	500' (150 m)
HDTV 1080i	<250' (75 m)	>300' (90 m)	300' (90 m)	400' (120 m)
HDTV 1080p	<250' (75 m)	>300' (90 m)	300' (90 m)	400' (120 m)

NOTE Resolutions marked with an asterisk (*) in the table above have the same range specifications at 75 Hz.

NOTE It is possible to exceed the recommended distance; however, image quality may be reduced.

NOTE Extron recommends using at least 25 feet of TP cable between the transmitter and the first receiver.

Installation and Operation

Installation

CAUTION

Installation and service must be performed by authorized personnel only.

The 1U high, quarter rack width, MTP transmitter and all receiver models can be mounted on a rack shelf, to a rack without a shelf, under a desk or tabletop, or on a projector bracket.

Rack mounting

UL guidelines

The following Underwriters Laboratories (UL) guidelines pertain to the installation of the MTP transmitter or receiver into a rack.

- 1. Elevated operating ambient temperature** — If the equipment is installed in a closed or multi-unit rack assembly, the operating ambient temperature of the rack environment may be greater than room ambient. Therefore, install the equipment in an environment compatible with the maximum ambient temperature (TMA) specified by Extron (TMA = +122 °F, +50 °C).
- 2. Reduced air flow** — Installation of the equipment in a rack should be such that the amount of air flow required for safe operation of the equipment is not compromised.
- 3. Mechanical loading** — Mounting of the equipment in the rack should be such that a hazardous condition is not achieved due to uneven mechanical loading.
- 4. Circuit overloading** — Consideration should be given to the connection of the equipment to the supply circuit and the effect that overloading of the circuits might have on overcurrent protection and supply wiring. Appropriate consideration of equipment nameplate ratings should be used when addressing this concern.
- 5. Reliable earthing (grounding)** — Reliable earthing of rack-mounted equipment should be maintained. Particular attention should be given to supply connections (such as the use of power strips) other than direct connections to the branch circuit.

Rack mounting instructions

For optional rack mounting, mount the MTP on any of the following rack shelves:

- RSF 123 - 1U 3.5 inch Deep Rack Shelf Kit (part number 60-190-20, see figure 1)
- RSB 123 - 1U 3.5 inch Deep Basic Rack Shelf (part number 60-604-21)
- RSU 126 - 1U 6 inch Deep Universal Rack Shelf Kit (part number 60-190-10)
- RSB 126 - 1U 6 inch Deep Basic Rack Shelf (part number 60-604-11)
- RSU 129 - 1U 9.5 inch Deep Universal Rack Shelf Kit (part number 60-190-01, see figure 2 on page 7)
- RSB 129 - 1U 9.5 inch Deep Basic Rack Shelf (part number 60-604-02)

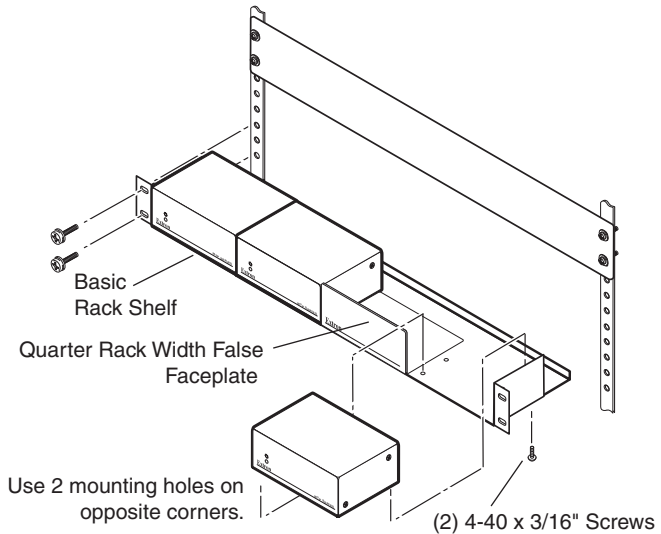

Figure 1 — Mounting the MTP on a 3.5" rack shelf

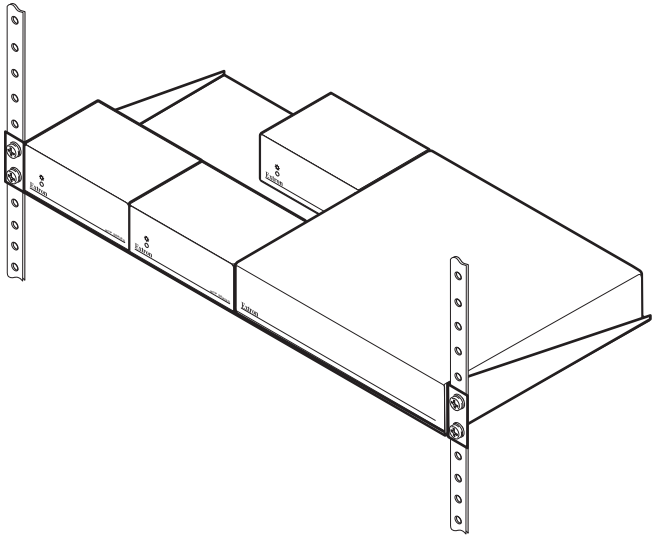

Figure 2 — Mounting the MTP on a standard shelf

On the larger rack shelves, the MTP can be mounted in the front or the rear of the rack.

1. Remove the feet from the bottom of the MTP if they are already installed.
2. Mount the MTP using two 4-40 x 3/16 inch screws in opposite (diagonal) corners to secure the MTP to the shelf.
3. Install false faceplate(s) or other unit(s) to the rack shelf.
4. Insert the shelf into the rack, aligning the holes in the shelf with those of the rack.
5. Secure the shelf to the rack using the supplied machine screws (see figure 2).

Back of the rack mounting instructions

The MTP can be mounted to the rear of a rack using the Extron MBB 100 1/8 and 1/4 Back of Rack Mounting Kit (part number 70-367-01) (see figure 3). The kit allows the product to be vertically mounted to the front or rear rack supports and facing either towards the front or the rear of the rack.

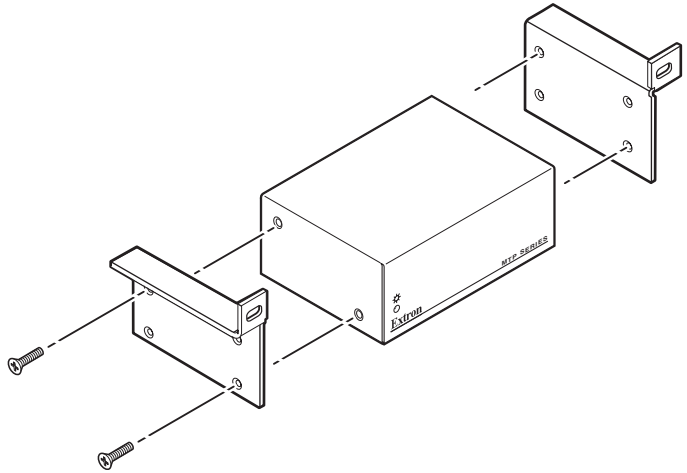

Figure 3 — Attaching the back of the rack kit

1. Remove the feet from the bottom of the MTP if they are installed.
2. Remove the two screws from one side of the unit. Retain the screws for possible later reassembly without the bracket.
3. Attach one bracket to the side of the unit using the longer screws included in the kit.
4. Repeat steps 2 and 3 on the other side of the unit.

Installation and Operation, cont'd

5. Mount the unit to the rack using the two included rack screws (see figure 4). The MTP can be vertically mounted facing in either direction.

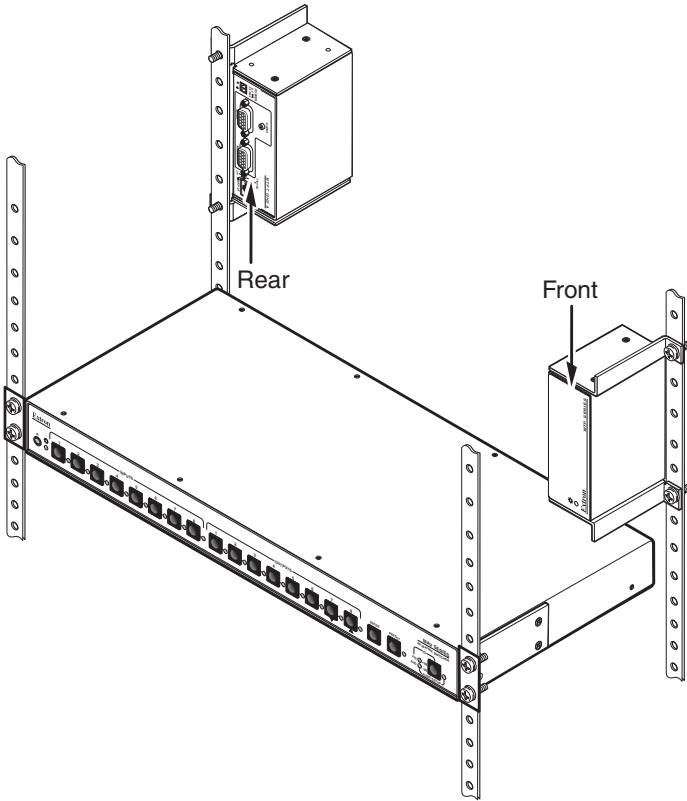

Figure 4 — Typical back of the rack installations

Furniture or projector mounting

Use one of the following optional mounting kits to mount the MTP under furniture or to a projector mount (see figure 5).

- MBU 123 Low-Profile Mount Kit, part number 70-212-01
- PMK 100 1/4 Rack Width Pole Mount Kit, part number 70-217-01

1. Remove the feet from the bottom of the MTP, if they are installed.
2. Attach the mounting brackets to the MTP with the provided machine screws.
3. **For furniture mounting**, hold the MTP with the attached brackets against the mounting surface. Mark the bracket screw hole locations on the mounting surface.
4. **For furniture mounting**, drill 3/32 inch (2 mm) diameter pilot holes, 1/4 inch (6.3 mm) deep in the mounting surface at the marked screw locations.
5. **For furniture mounting**, insert number 8 wood screws into the four pilot holes. Tighten each screw into the mounting surface until just less than 1/4 inch (6 mm) of the screw head protrudes.
6. **For furniture mounting**, align the mounting screws with the slots in the brackets and place the MTP against the surface, with the screws through the bracket slots.
7. **For furniture mounting**, slide the MTP slightly forward or back, then tighten all four screws to secure the MTP in place.
8. **For projector mounting**, secure the MTP to a projector mount by inserting the mounting bolt through the slotted hole on the bracket and tightening the bolt.

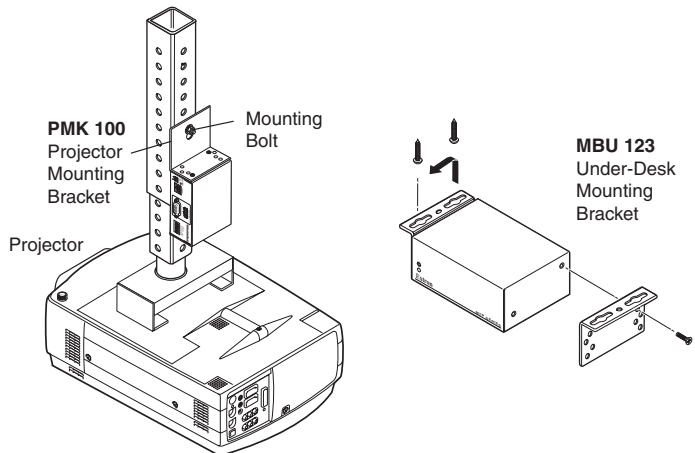

Figure 5 — Desk and projector mounting the MTPs

Connections and Settings

CAUTION

Do not connect these devices to a computer data or telecommunications network.

Transmitter

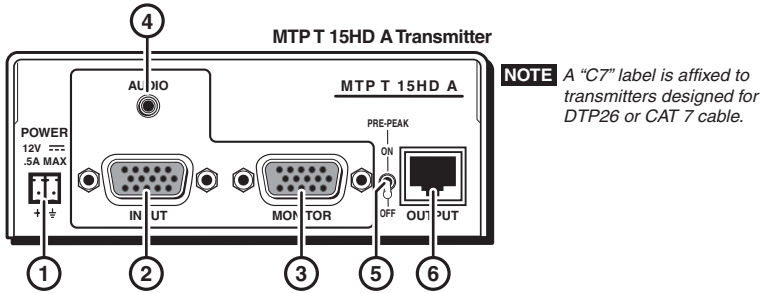

Figure 6 — Transmitter rear panel features

Power connection

- 1 Power connector — Plug the included external 12 VDC power supply into this 2-pole captive screw connector. See “Power supply wiring” on page 16 to wire the connector.

Video and audio connections

- 2 Input video connector — Connect a computer video source to this 15-pin HD connector for high resolution video input.

NOTE

Input only sync signals, no video signals, on the sync pins (13 and 14).

For component video, use the R (R-Y) and R return pins (pins 1 and 6), G (Y) and G return pins (pins 2 and 7), and B (B-Y) and B return pins (pins 3 and 8). For S-video, use the R, R return (C-chroma), G, and G return (Y-luma) pins.

For composite video, use the G pin and the associated return pin. For additional genlocked video signals, use the R, B, and associated return pins.

- 3 Monitor connector — Connect a video monitor to this 15-pin HD connector for buffered, high resolution video loop-through.

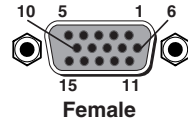

-
- ④ **Audio input connector** — Plug a 3.5 mm stereo audio plug into this jack for unbalanced audio input. Wire the plug as shown in figure 7.

AUDIO

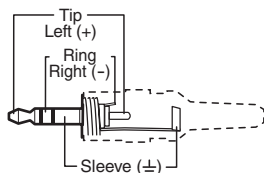

Figure 7 — 3.5 mm stereo audio plug

The stereo audio input is summed and output on the TP cable as mono audio.

Twisted pair connection and settings

- ⑤ **Pre-Peak switch** — The Pre-Peak switch alters the TP signal output to correct for long cable runs. See the table on page 4 for suggested switch settings based on the transmitted video format and transmission distance.
- ⑥ **Output connector** — Connect one end of a TP cable to this RJ-45 female connector on the transmitter.

Connect the free end of the same TP cable to the RJ-45 female connector on the receiver. See “TP cable termination” on page 17 to wire the RJ-45 connectors.

Installation and Operation, cont'd

Receiver

Figure 8 shows an MTP RL 15HD A receiver, which has all of the connectors and other features that are on either receiver in the MTP 15HD A series.

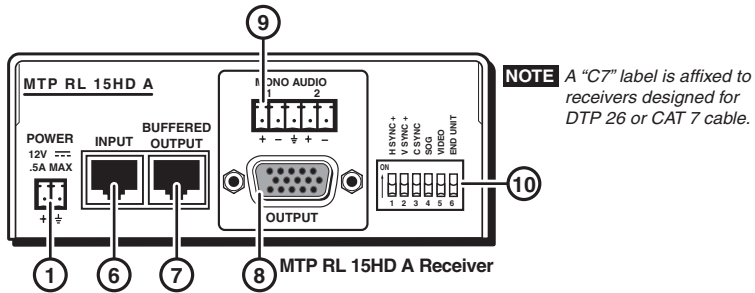

Figure 8 — Receiver rear panel features

Power connection

- ① **Power connector** — Plug the included external 12 VDC power supply into this 2-pole captive screw connector. See “[Power supply wiring](#)” on page 16 to wire the connector.

Twisted pair connections

- ⑥ **Input connector** — Connect one end of the TP cable from the transmitter or from the Buffered Output connector of an RL receiver to this RJ-45 female connector. See “[TP cable termination](#)” on page 17 to wire the RJ-45 connectors.
- ⑦ **Buffered Output connector (RL receivers only)** — Connect one end of a TP cable to this RJ-45 female connector. Connect the free end of the same TP cable from the receiver to the Input RJ-45 female connector on another receiver.

See “[TP cable termination](#)” on page 17 to wire the RJ-45 connectors.

NOTE *The buffered output on the RL receiver does not provide pre-peaking control. The total recommended distance for an entire daisy chain is the same as for a single transmitter and receiver. The Pre-Peak switch has the same effect on the recommended transmission distance for a daisy chain as for a single transmitter and receiver.*

NOTE *Up to eight receivers can be connected in series using Buffered Output connectors, provided that the total distance from the TP output of the transmitter to the last receiver in the chain does not exceed the recommended distance for the resolution being used.*

NOTE

See the [table on page 4](#) for recommended transmission ranges. The recommendations in the table apply equally for a single transmitter and receiver and for a daisy chain. For example, the maximum suggested range for 1024 x 768 video is 300 feet (90 m) with the Pre-Peak switch off and 500 feet (150 m) with the Pre-Peak switch on for either one transmitter and one receiver or a transmitter and three daisy-chained receivers.

NOTE

For daisy-chained units, the first receiver in the chain must be at least 100 feet (30 m) from the transmitter when the Pre-Peak switch is on.

NOTE

For daisy-chained units, any receiver in the chain closer than 350 feet (105 m) may experience some form of over-peaking when the Pre-Peak switch is on.

NOTE

If a receiver is the last receiver in a daisy chain, its End Unit DIP Switch setting may need to be changed. See “DIP switches”, [item 10](#), on the page 15.

Video and audio connections and settings

- 8 **Output video connector** — Connect a projector or other high resolution video device to this 15-pin HD connector.
- 9 **Mono Audio output connector** — Insert a 3.5 mm, 5-pole captive screw audio connector into this connector for two mono audio outputs. Wire the connector as shown in figure 9. Use the supplied tie-wrap to strap the audio cable to the extended tail of the connector.

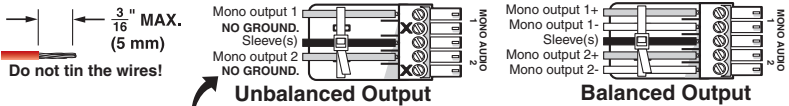
**CAUTION**

For unbalanced audio, connect the sleeve(s) to the ground contact.
DO NOT connect the sleeve(s) to the negative (-) contacts.

Figure 9 — Captive screw audio connector wiring

CAUTION

The length of the exposed (stripped) portion of the copper wires is important. The ideal length is $\frac{3}{16}$ inches (5 mm). Longer bare wires can short together. Shorter bare wires are not as secure in the direct insertion connectors and could be pulled out.

Installation and Operation, cont'd

10 DIP switches

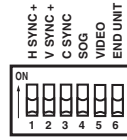

Horizontal Sync (H Sync +) switch — Set this switch up for positive horizontal sync (or positive composite sync if the Composite Sync switch is on) or down for negative sync.

Vertical Sync (V Sync +) switch — Set this switch up for positive vertical sync or down for negative sync.

NOTE For H Sync + and V Sync +, most devices use negative sync.

Composite Sync (C Sync) switch — Set this switch up for RGBS or down to output RGBHV or RGsB video. See the table below.

Input signal format to the transmitter	Output signal format from the receiver	Receiver's DIP switch settings		
		C Sync	SOG	Video
RGBHV	RGBHV			
	RGBS			
	RGsB			
RGBS	RGBS			
	RGsB			
RsGsBs	RsGsBs			
RGsB	RGsB			
Component	Component			
S-video	S-video			
Composite	Composite			

Sync-on-Green (SOG) switch — Set this switch up for RGsB video (when the input is RGBHV or RGBS) or down to output RGBHV, RsGsBs, or RGBS video. See the table above.

Video switch — Set this switch up for RsGsBs, RGsB, component/S-video/composite video or down to output RGBHV or RGBS video. See the table above.

NOTE Set the Composite Sync, SOG, and Video DIP switches as shown in the table above for the various input and output video formats.

End Unit switch — Set this switch **up** if **either** of the following is true:

- The receiver being configured is the only receiver connected to the transmitter.
- The receiver being configured is the last receiver in a daisy-chained system.

Set the End Unit switch **down** on the receiver being configured if there are one or more receivers connected to the Buffered Output RJ-45 connector.

Power supply wiring

Figure 10 shows how to wire the power connector.

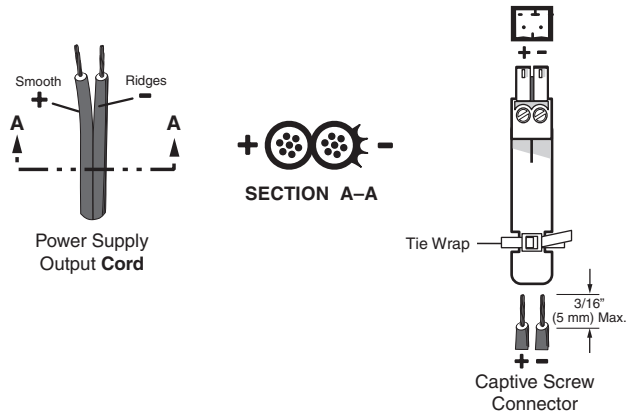

Figure 10 — Power connector wiring

CAUTION *Power supply voltage polarity is critical. Incorrect voltage polarity can damage the power supply and the MTP. Identify the power cord negative lead by the ridges on the side of the cord (see figure 10).*

To verify the polarity before connection, plug in the power supply with no load and check the output with a voltmeter.

WARNING *The two power cord wires must be kept separate while the power supply is plugged in. Remove power before wiring.*

CAUTION *The length of the exposed (stripped) copper wires is important. The ideal length is 3/16 inches (5 mm). Longer bare wires can short together. Shorter wires are not as secure in the direct insertion connectors and could be pulled out.*

Installation and Operation, cont'd

NOTE Do not tin the power supply leads before installing them in the direct insertion connector. Tinned wires are not as secure in the connectors and could be pulled out.

Use the supplied tie-wrap to strap the power cord to the extended tail of the connector.

NOTE Your transmitter/receiver pair may have shipped with a blue captive screw connector. This blue connector can be plugged into either a blue or an orange power receptacle.

The blue connector does not have the extended tail or the included tie-wrap.

Alternatively, an optional Extron PS 124 Universal 12 VDC Power Supply, part number **60-1022-01**, can power multiple Extron 12 VDC devices using only one AC power connector.

TP cable termination

NOTE RJ-45 termination with CAT 5, 5e, or 6 cable (for non-C7 units **only**) or DTP26 or CAT 7 cable (for C7 units **only**) must comply with the TIA/EIA T568A or TIA/EIA T568B wiring standards for all connections.

*RJ-45 termination with Skew-Free A/V UTP cable (for non-C7 units **only**) must comply with TIA/EIA T568A only.*

NOTE The non-C7 transmitters and receivers will not work properly with DTP26 or CAT 7 STP cable.

*The C7 transmitters and receivers will work properly **only with** DTP26 or CAT 7 STP cable.*

Figure 11 on page 18 details the recommended termination of TP cables with RJ-45 connectors in accordance with the TIA/EIA T568A or TIA/EIA T568B wiring standards. You can use either standard with CAT 5, 5e, 6, 7, and DTP26 cable, but ensure that you **use the same standard on both ends of the cable.**

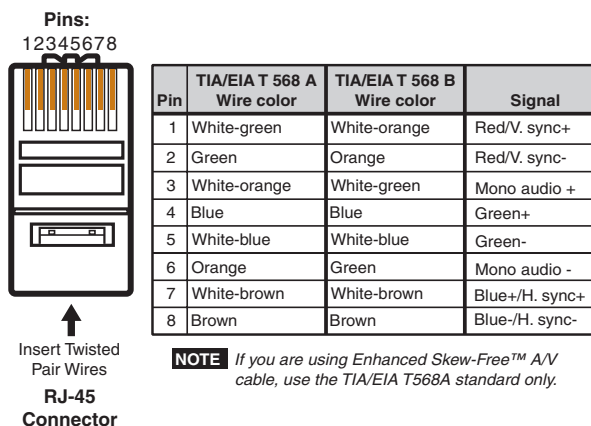

Figure 11 — TP cable termination

NOTE For proper grounding of DTP26 and CAT 7 cable only, ensure the shield around each wire pair and the shield around the DTP26 or CAT 7 cable are all tied to the RJ-45 connectors on both ends, in accordance with the connector manufacturer specifications.

NOTE The audio data that is carried on wire pair 3 and 6 is incompatible with the Extron TPX 88 A, which cannot switch the audio, output it locally, or break it away.

NOTE Extron Enhanced Skew-Free A/V cable is **not recommended** for Ethernet/LAN applications. This cable is specially designed for compatibility with Extron Twisted Pair products that are wired using the TIA/EIA T568A standard.

The green, brown, and blue wire pairs of this cable have virtually identical lengths and should be used to transmit the RGB signals.

The orange wire pair of this cable has a different length and **should not** be used to transmit the RGB signals.

Front Panel Controls and Indicators

See figure 12 to identify the front panel features on the transmitter and receiver.

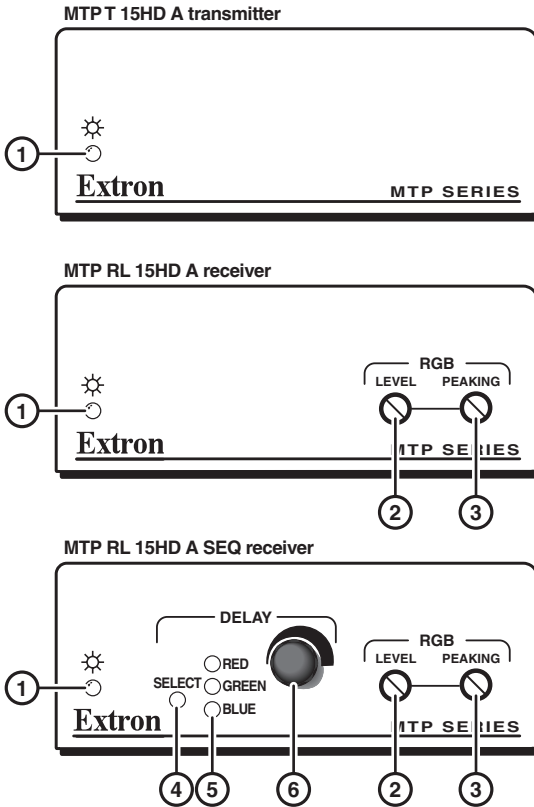

Figure 12 — MTP front panels

- ① **Power LED** — This LED indicates power is applied to the MTP.
- ② **Level control** — The Level control alters the video output voltage to affect the brightness of the displayed image. Adjust the knob while viewing the displayed image to set the level/boost that provides the best picture quality.

NOTE *For best results when using an RL receiver, connect a load to the buffered output on the receiver before adjusting the level.*

③ **Peaking control** — Peaking affects the sharpness of a picture. Increased peaking can compensate for mid- and high-frequency detail loss from low bandwidth system components or capacitance in long cables. The minimum setting (at the counterclockwise limit) provides no peaking. The maximum setting (at the clockwise limit) provides 100% peaking. Adjust this control to obtain the optimum picture sharpness.

④ **Select button (SEQ model only)** — This recessed button selects the Red, Green, or Blue video signal to adjust and resets all three video signals to a skew delay of zero nanoseconds.

Use a small screwdriver to press and release this button to cycle among selecting the Red, Green, or Blue video signal to adjust. The selected signal is indicated by the Red, Green, and Blue LEDs (⑤).

NOTE *The SEQ receiver automatically saves the setting for the video signal that is being deselected when you push this button or when the selection times out after 10 seconds.*

Press and **hold** this button for approximately 3 seconds to set the skew delay for Red, Green, and Blue to zero. The Red, Green, and Blue LEDs (⑤) all turn off. Release the button.

⑤ **Red, Green, and Blue LEDs (SEQ model only)** — These LEDs indicate the video signal that is selected by the Select button (④) for skew adjustment using the Delay control (⑥). The LED of the selected color flashes when skew compensation for the selected video signal has reached the minimum or maximum limit.

⑥ **Delay (skew adjustment) control (SEQ model only)** — This control delays the selected Red, Green, or Blue video signal by up to 62 nanoseconds. The delay is applied in incremental, 2-nanosecond steps. Rotate the control counterclockwise to reduce the delay or clockwise to increase the delay.

NOTE *The control turns smoothly; it does not have mechanical steps or high-and low-limit stops.*

Watch the displayed image to observe the steps of delay.

The selected Red, Green, or Blue LED (⑤) flashes to indicate that the control has reached the minimum (counterclockwise rotation) or maximum (clockwise rotation) limit.

Skew Delay Compensation

CAT 5, 5e, 6, 7, and DTP26 cable can lead to registration errors between the Red, Green, and Blue video signals. Pair skew can be measured with test equipment or identified by viewing a crosshatch test pattern with a critical eye to determine if either the Red, Green, or Blue video image leads (appears to the left of) the other two video images.

NOTE *Unless the TP cable is changed, the skew adjustment should need to be made only once, during installation.*

SEQ receiver skew compensation

The SEQ receiver has built-in skew compensation capabilities. Adjust the equalization as follows:

1. **Zero the skew delay** for Red, Green, and Blue as follows:
 - a. Use a small screwdriver to press and **hold** the Select button for 3 seconds. The Red, Green, and Blue LEDs all go out.
 - b. Release the Select button.
2. Use UTP cable test equipment or examine the displayed video image with a critical eye to **determine which video signal** — Red, Green, or Blue — **is most shifted to the left**.

NOTE *A crosshatch test pattern or a black background with vertical white lines is ideal for determining skew.*

3. **Adjust the leftmost video signal** as follows:

NOTE *The SEQ receiver **cannot** shift the rightmost video image to the left.*

- a. Use a small screwdriver to press and release the Select button until the LED lights for the left-shifted color — Red, Green, or Blue.
- b. *Slowly* rotate the Delay control clockwise while monitoring the display. Observe that the leftmost color shifts rightward one step at a time. Continue to rotate the control until that color is properly converged.

NOTE *A 2-nanosecond adjustment is very fine. Up to 10 nanoseconds of delay may be necessary before you detect a change in the display.*

- c. Use a small screwdriver to press the Select button one more time to save the most recent adjustment or allow the 10-second timeout to elapse.
4. If the remaining colors are left shifted, repeat steps 2 and 3.

Non-SEQ receiver skew compensation

Try using the following methods to minimize or eliminate pair skew:

- Switch to Extron Enhanced Skew-Free A/V UTP cable.
- Add a skew compensation cable equal to the length of pair skew to the output of the receiver.
- Install a SEQ 100 15HD Skew Equalizer to the video output of the receiver and adjust the skew for the leading video image.

Reference Information

Specifications

Video

Gain	Unity
Number/signal type	1 set of proprietary analog signals
Connectors	1 female RJ-45

Video input and loop through — transmitters

Number/signal type	1 analog RGBHV, RGBS, RGsB, RsGsBs, component video, S-video, or composite video 1 buffered RGBHV, RGBS, RGsB, RsGsBs local monitor loop through (includes ID bits)
Connectors	2 female 15-pin HD
Nominal level	1 Vp-p for Y of component video and S-video, and for composite video 0.7 Vp-p for RGB and for R-Y and B-Y of component video 0.3 Vp-p for C of S-video
Minimum/maximum levels	0.3 V to 1.45 Vp-p
Impedance	75 ohms
Horizontal frequency	15 kHz to 130 kHz
Vertical frequency	30 Hz to 150 Hz
Return loss	<-30 dB @ 5 MHz
DC offset (max. allowable)	250 mV

Video output — receivers

Number/signal type	1 set of proprietary analog signals 1 analog RGBHV, RGBS, RGsB, RsGsBs, component video, S-video, or composite video
Connectors	1 female RJ-45 1 female 15-pin HD
Nominal level	1 Vp-p for Y of component video and S-video, and for composite video 0.7 Vp-p for RGB and for R-Y and B-Y of component video 0.3 Vp-p for C of S-video
Minimum/maximum levels	0.3 V to 1.45 Vp-p
Impedance	75 ohms
Return loss	<-30 dB @ 5 MHz
DC offset (max. allowable)	±35 mV with input at 0 offset

Skew compensation	62 ns
Signal transmission distance	Up to 1920x1200 or 2048x1080 or 1080p at 300' Up to 1024x768 at 600'

Sync

Input type (transmitters)	RGBHV, RGBS, RGsB, RsGsBs
Output type (receivers)	RGBHV, RGBS, RGsB, RsGsBs
Standards	NTSC 3.58, NTSC 4.43, PAL, SECAM
Input level (transmitters)	3.5 V to 5.5 V _{p-p} , unterminated
Output level (receivers)	4.0 V to 5.0 V _{p-p} , unterminated
Input impedance (transmitters) ..	573 ohms ±5%
Output impedance (receivers)	
C7 models	92 ohms ±8% (25 mA)
All other models	110 ohms
Max. input voltage (transmitters)	5.5 V _{p-p}
Polarity	
Transmitter	Positive or negative (follows input polarity)
Receivers	Positive or negative (switch-selectable)

Audio

Number/signal type	1 set of proprietary analog signals
Connectors	1 female RJ-45
Gain	Unbalanced output: 0 dB; balanced output: +6 dB
Frequency response	20 Hz to 20 kHz, ±1 dB
THD + Noise	0.15% @ 1 kHz, 0.3% @ 20 kHz at nominal level
S/N	>70 dB at maximum output (unweighted)
Stereo channel separation	>60 dB @ 1kHz
CMRR	>43 dB @ 20 Hz to 20 kHz

Audio input — transmitters

Number/signal type	1 stereo, unbalanced
Connectors	(1) 3.5 mm mini stereo jack
Impedance	10k ohms ±1%, unbalanced
Nominal level	+4 dBu (1.23 V _{rms}), -10 dBV (316 mV _{rms})
Maximum level	
C7 models	±12 dBu, (unbalanced) at 1% THD+N
All other models	+18 dBu, (unbalanced) at 1% THD+N

NOTE 0 dBu = 0.775 V_{rms}, 0 dBV = 1 V_{rms}, 0 dBV ≈ 2 dBu

Reference Information, cont'd

Audio output — receivers

Number/signal type	2 mono, balanced/unbalanced
Connectors	(1) 3.5 mm captive screw connector, 5 pole
Impedance	50 ohms unbalanced, 100 ohms balanced
Gain error	±1 dB channel to channel
Nominal level	+4 dBu (1.23 Vrms), -10 dBV (316 mVrms)
Maximum level	+18 dBu, unbalanced at 1% THD+N

General

Required cable type	
C7 models	Extron DTP26 or CAT 7
All other models	CAT 5/5E/6 (shielded or unshielded)
External power supply	100 VAC to 240 VAC, 50-60 Hz, external; to 12 VDC, 1 A, regulated
Power input requirements	12 VDC, 0.5 A
Temperature/humidity	Storage: -40 to +158 °F (-40 to +70 °C)/ 10% to 90%, noncondensing Operating: +32 to +122 °F (0 to +50 °C)/ 10% to 90%, noncondensing
Cooling	Convection, no vents
Mounting	
Rack mount	Yes, with optional 1U rack shelf
Furniture mount	Yes, with optional Mini Under-Desk Mounting Kit
Pole mount	Yes, with optional pole mounting kit
Enclosure type	Metal
Enclosure dimensions	1.7" H x 4.3" W x 3.0" D (1U high, quarter rack wide) 4.3 cm H x 10.9 cm W x 7.6 cm D (Depth excludes connectors and knobs.)
Product weight	0.4 lbs (0.2 kg)
Shipping weight	2 lbs (1 kg)
Vibration	ISTA 1A in carton (International Safe Transit Association)
Regulatory compliance	
Safety	CE, c-UL, UL
EMI/EMC	CE, C-tick, FCC Class A, ICES, VCCI
MTBF	30,000 hours
Warranty	3 years parts and labor

NOTE All nominal levels are at ±10%.

NOTE Specifications are subject to change without notice.

Part Numbers

MTP transmitter and receivers for non-CAT 7 cable

Part	Part number
MTP T 15HD A transmitter	60-669-01
MTP RL 15HD A receiver	60-690-01
MTP RL 15HD A SEQ receiver	60-690-02

MTP transmitter and receivers for DTP26 and CAT 7 cable

Part	Part number
MTP C7 T 15HD A transmitter	60-669-02
MTP C7 RL 15HD A receiver	60-690-03
MTP C7 RL 15HD A SEQ receiver	60-690-04

Included parts

Part	
12 VDC power supply	28-071-57LF
MTP transmitter and receiver guide	
IEC power cord	
Rubber feet	

Accessories

Accessories	Part number
PS 124 Multiple Output 12 V DC Power Supply	60-1022-01
RSU 129 19" 1U 9.5" Deep Universal Rack Shelf Kit	60-190-01
RSB 129 19" 1U 9.5" Deep Basic Rack Shelf	60-604-02
RSU 126 1U 6" Deep Universal Rack Shelf Kit	60-190-10
RSB 126 1U 6" Deep Basic Rack Shelf	60-604-11
RSF 123 3.5" Deep Rack Shelf Kit	60-190-20
RSB 123 3.5" Deep Basic Rack Shelf	60-604-21
MBB 100 1/8 and 1/4 Back of Rack Mounting Kit	70-367-01
MBU 123 Low-profile Mount Kit	70-212-01
PMK 100 1/4 Rack Width Pole Mount Kit	70-217-01

Reference Information, cont'd

Cables/connectors

NOTE *Extron Enhanced Skew-Free™ A/V UTP cables are not recommended for Ethernet/LAN applications.*

NOTE *Extron Enhanced Skew-Free A/V UTP cables are recommended for **non-C7** systems only.*

Extron Enhanced Skew-Free A/V cable Part number

Extron Enhanced Skew-Free A/V cable
(cut, various lengths) 26-569-xx

Extron Enhanced Skew-Free A/V 1000'
(bulk) (Non-Plenum) 22-141-03

Extron Enhanced Skew-Free A/V 1000'
(bulk) (Plenum) 22-142-03

NOTE *DTP26 or CAT 7 cables are recommended for C7 systems only.*

DTP26 cable

DTP26/1000 Non-Plenum 1000' (300 m) spool 22-214-03

DTP26P/1000 Plenum 1000' (300 m) spool 22-215-03

RJ-45 connectors

Part number

CAT 6 jack (Black), qty. 10 100-476-01

CAT 6 jack (Red), qty. 10 100-477-01

CAT 6 jack (Blue), qty. 10 100-478-01

CAT 6 jack (Orange), qty. 10 100-479-01

CAT 6 jack (Gray), qty. 10 100-480-01

CAT 6 jack (White), qty. 10 100-481-01

CAT 6 jack (Ivory), qty. 10 100-482-01

Shielded RJ-45 for DTP26 cable 101-005-01

Extron Warranty

Extron Electronics warrants this product against defects in materials and workmanship for a period of three years from the date of purchase. In the event of malfunction during the warranty period attributable directly to faulty workmanship and/or materials, Extron Electronics will, at its option, repair or replace said products or components, to whatever extent it shall deem necessary to restore said product to proper operating condition, provided that it is returned within the warranty period, with proof of purchase and description of malfunction to:

USA, Canada, South America, and Central America:

Extron USA
1001 East Ball Road
Anaheim, CA 92805
U.S.A.

Europe, Africa, and the Middle East:

Extron Europe
Hanzeboulevard 10
3825 PH Amersfoort
The Netherlands

Asia:

Extron Asia
135 Joo Seng Road #04-01
PM Industrial Bldg.
Singapore 368363
Singapore

Japan:

Extron Japan
Kyodo Building, 16 Ichibancho
Chiyoda-ku, Tokyo 102-0082
Japan

China:

Extron China
686 Ronghua Road, Songjiang
District
Shanghai 201611
China

Middle East:

Extron Middle East
Dubai Airport Free Zone
F12, PO Box 293666
United Arab Emirates, Dubai

This Limited Warranty does not apply if the fault has been caused by misuse, improper handling care, electrical or mechanical abuse, abnormal operating conditions or non-Extron authorized modification to the product.

If it has been determined that the product is defective, please call Extron and ask for an Applications Engineer at (714) 491-1500 (USA), 31.33.453.4040 (Europe), 65.6383.4400 (Asia), or 81.3.3511.7655 (Japan) to receive an RA# (Return Authorization number). This will begin the repair process as quickly as possible.

Units must be returned insured, with shipping charges prepaid. If not insured, you assume the risk of loss or damage during shipment. Returned units must include the serial number and a description of the problem, as well as the name of the person to contact in case there are any questions.

Extron Electronics makes no further warranties either expressed or implied with respect to the product and its quality, performance, merchantability, or fitness for any particular use. In no event will Extron Electronics be liable for direct, indirect, or consequential damages resulting from any defect in this product even if Extron Electronics has been advised of such damage.

Please note that laws vary from state to state and country to country, and that some provisions of this warranty may not apply to you.

Extron USA - West
Headquarters

+800.633.9876
Inside USA / Canada Only
+1.714.491.1500
+1.714.491.1517 FAX

Extron USA - East

+800.633.9876
Inside USA / Canada Only
+1.919.863.1794
+1.919.863.1797 FAX

Extron Europe

+800.3987.6673
Inside Europe Only
+31.33.453.4040
+31.33.453.4050 FAX

Extron Asia

+800.7339.8766
Inside Asia Only
+65.6383.4400
+65.6383.4664 FAX

Extron Japan

+81.3.3511.7655
+81.3.3511.7656 FAX

Extron China

+400.883.1568
Inside China Only
+86.21.3760.1568
+86.21.3760.1566 FAX

Extron Middle East

+971.4.2991800
+971.4.2991880 FAX